

WHEEL STRIPE

Accessory Name	Parts Number	Application Model	Issue Date	Publication No.	FRT
17 INCH WHEEL STRIPE	08F74-K3S-JA0	CL500A	2022.12	MII	0.3 H
19 INCH WHEEL STRIPE	08F75-K3S-JA0				0.3 H

Introduction

ALL INFORMATION, ILLUSTRATIONS, DIRECTIONS AND SPECIFICATIONS INCLUDED IN THIS PUBLICATION ARE BASED ON THE LATEST PRODUCT INFORMATION AVAILABLE AT THE TIME OF APPROVAL FOR PRINTING. Honda Motor Co., Ltd. RESERVES THE RIGHT TO MAKE CHANGES AT ANY TIME WITHOUT NOTICE AND WITHOUT INCURRING ANY OBLIGATION WHATSOEVER. NO PART OF THIS PUBLICATION MAY BE REPRODUCED WITHOUT WRITTEN PERMISSION. THIS MANUAL IS WRITTEN FOR PERSONS WHO HAVE ACQUIRED BASIC KNOWLEDGE OF MAINTENANCE ON Honda MOTORCYCLES, MOTOR SCOOTERS OR ATVS.

Honda Dealer:







Please give a copy of these instructions to your customer.

Customer:

Because it requires specialized knowledge and special tools and equipment, it is recommended to install it at a dealer with qualified automobile maintenance.

How To Read These Symbols

Your safety, and the safety of others, is very important. To help you make informed decisions we have provided safety messages and other information throughout this manual.

-  **WARNING** You CAN be KILLED or SERIOUSLY HURT if you don't follow instructions.
-  **CAUTION** You CAN be HURT if you don't follow instructions.
-  **NOTICE** The purpose of this message is to help prevent damage to your vehicle, other property, or the environment.
-  **NOTE** Things you want to know, things that are useful to know.
-  Follow the instructions of the Service Manual.
-  Follow the other symbol instructions of the "Installation Instructions BASIC".

Instruction Other Symbols

The symbols used throughout this instructions show specific service procedures. Refer to "Installation Instructions BASIC" for description of each symbol.

INFORMATION

⚠ CAUTION

- To prevent burns, allow the engine, exhaust system, radiator, etc., to cool before installing the accessory.

NOTE:

- Heat the bonding surfaces with a hair dryer if the ambient air temperature is below 70°F (21°C).
- The adhesive reaches full strength in 72 hours. Wait at least 24 hours before riding your motorcycle.
- To neatly attach this accessory, attach it while lifting the tire with the maintenance stand or similar and adjusting the space between the wheel stripe and rim.

PARTS LIST

When the instruction manual and installation instructions are included in this kit, be sure to give them to the customer.

<17 INCH WHEEL STRIPE>

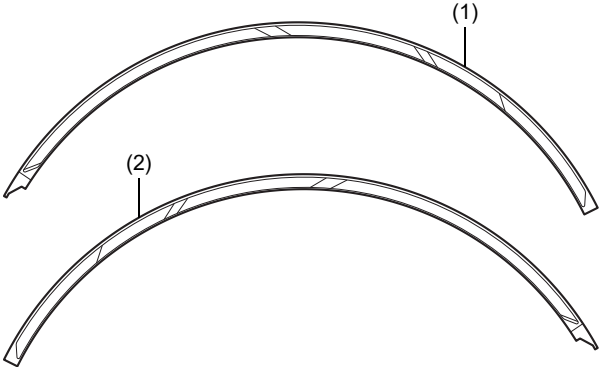
Component	No.	Parts Name	Qty	Parts No.
	(1)	Right wheel stripe	3	-
	(2)	Left wheel stripe	3	-

<19 INCH WHEEL STRIPE>

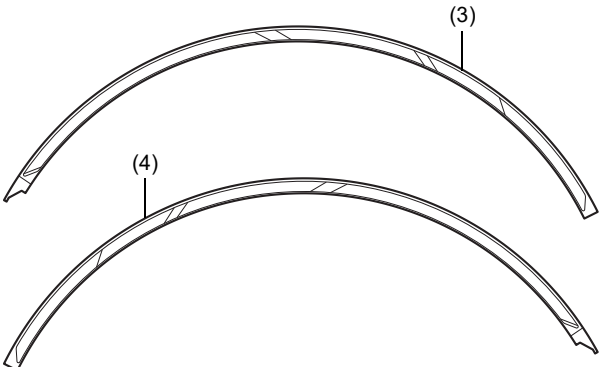
Component	No.	Parts Name	Qty	Parts No.
	(3)	Right front wheel stripe	3	-
	(4)	Left front wheel stripe	3	-

INSTALLATION

INSTALLATION IMAGE

- Attach the three wheel stripes to the one side of the wheel as shown.

<Front>

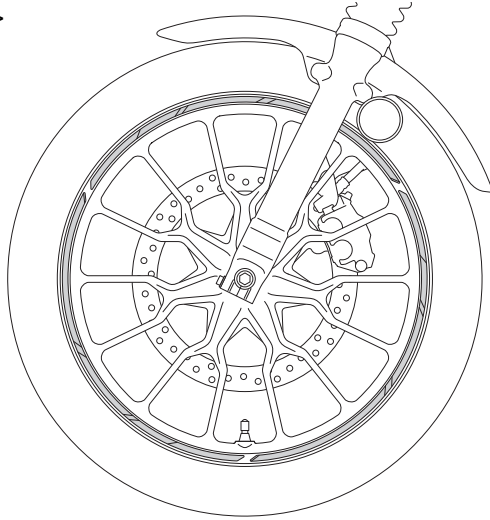

<Rear>

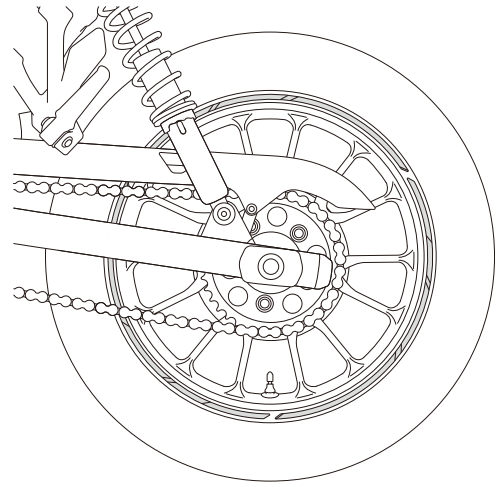

1. Clean the surface of the area shown using an isopropyl alcohol.

<Left side>

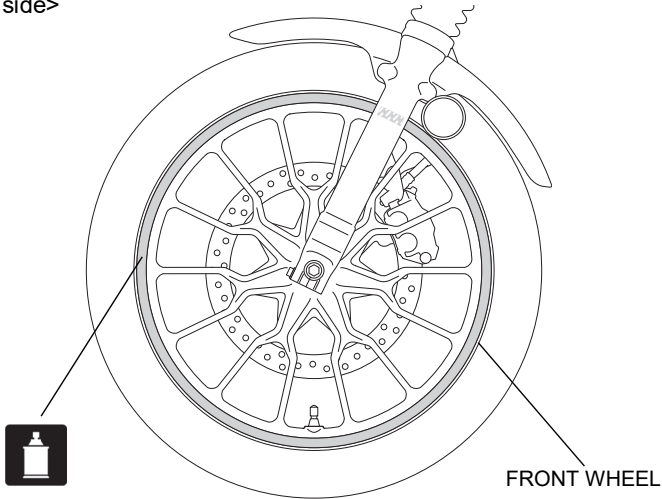

2. Partly remove the adhesive backing from behind the wheel stripe as shown.

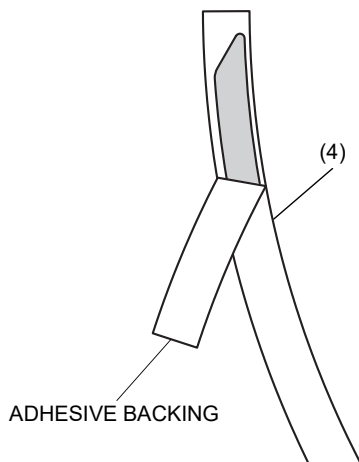

Attach the stripe according to the identification mark.

<for Left side>

(4)

GUIDE

<for Right side>

(3)

GUIDE

Installation Instructions

3. Attach the left front wheel stripe guiding its edge of the application film along the inside of the rim contour in a clockwise direction.
- Being careful not to allow air bubbles, glue on the wheel stripe while adjusting the space between the wheel stripe and the rim.
 - Do not glue on while pulling and stretching the stripe.

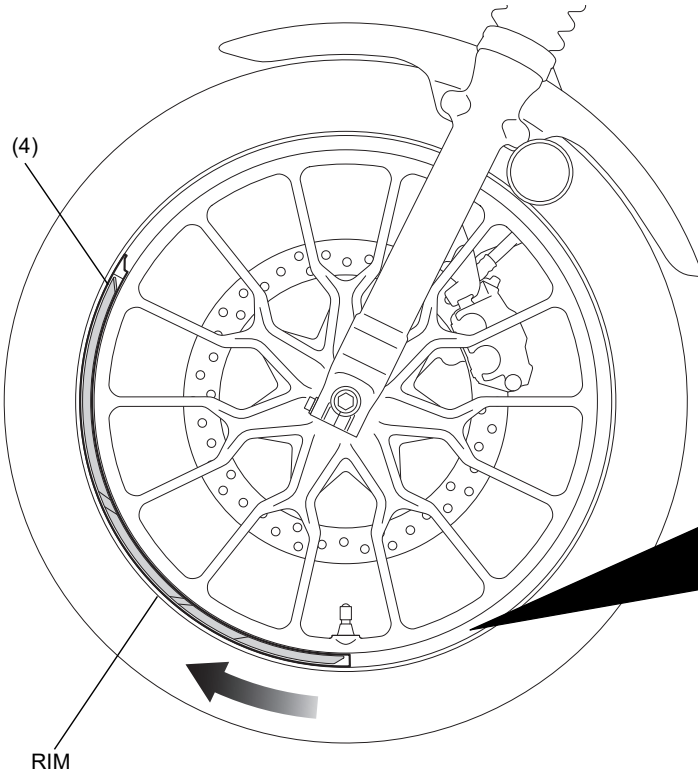

Align the edge of the left front wheel stripe with the center of the valve as shown.

Edge of the application film.

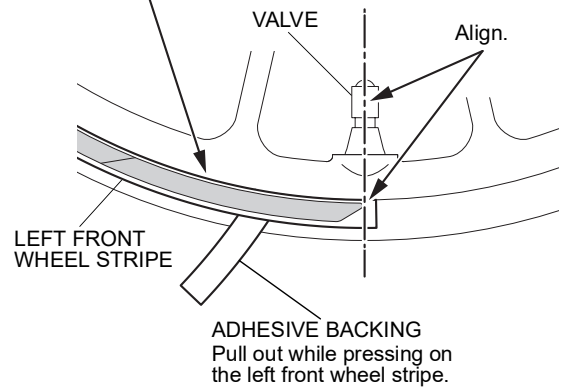

4. Peel off the application film.
- Do not peel off the guide.

Using a shop towel, force out excessive air.

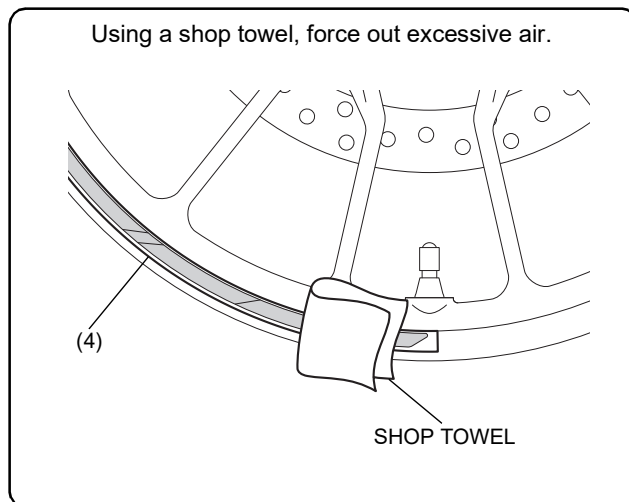

APPLICATION FILM

GUIDE

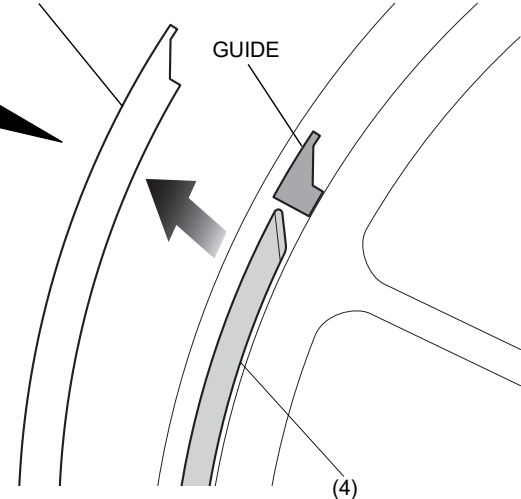

5. Partly remove the adhesive backing from behind the second left front wheel stripe.

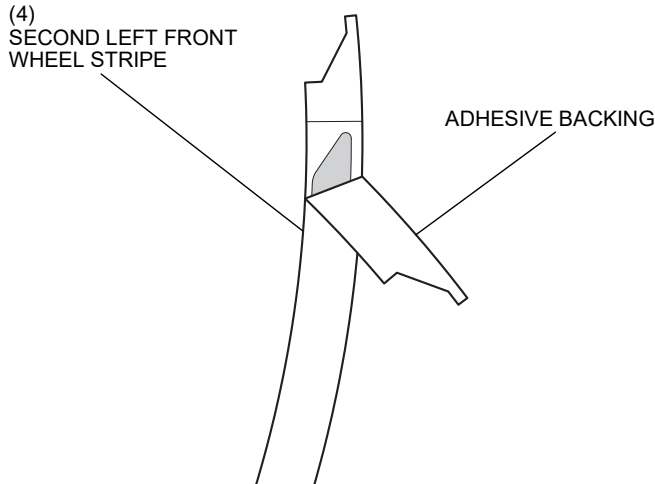

6. Attach the second left front wheel stripe guiding its edge of the application film along the inside of the rim contour in a counter-clockwise direction.

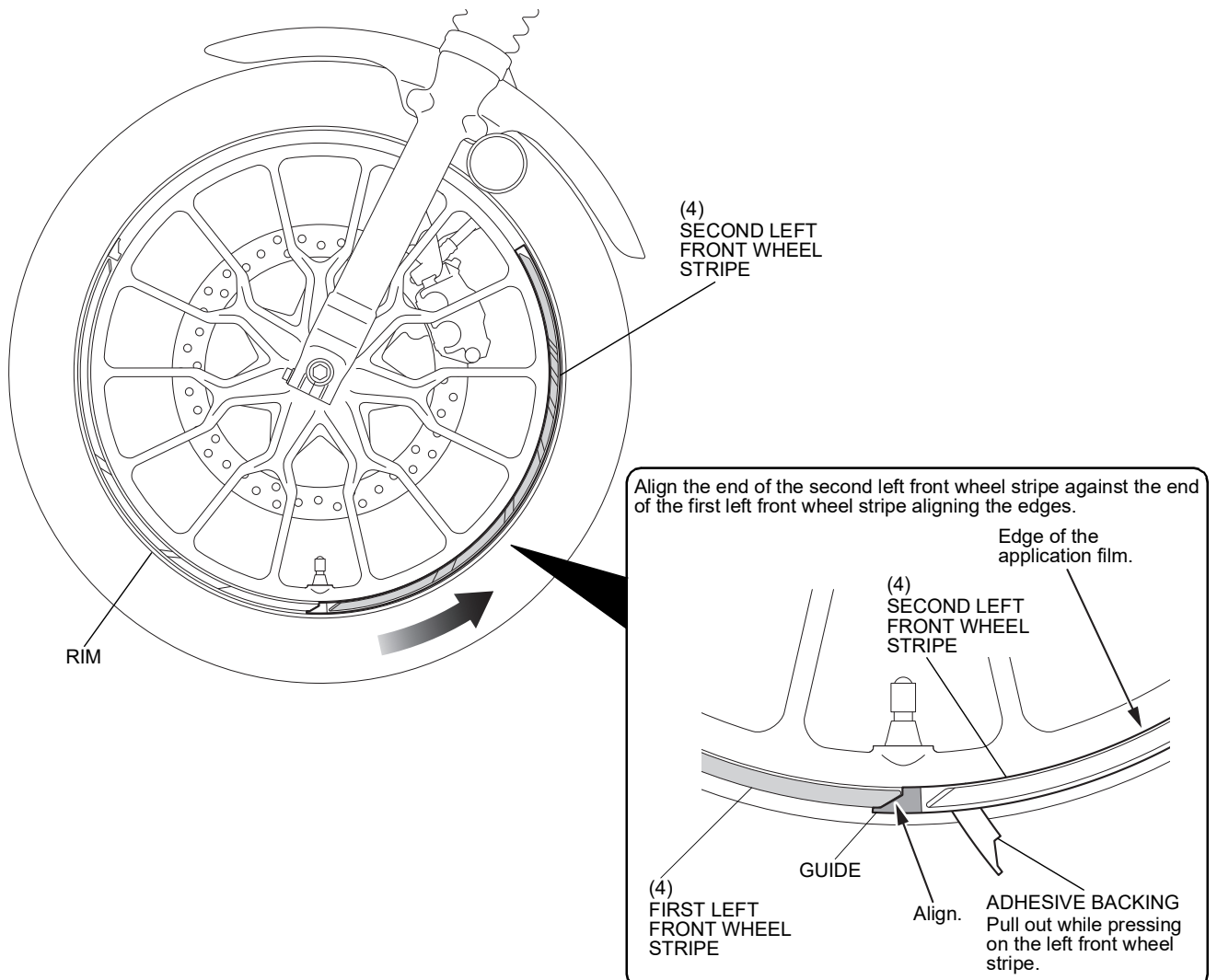

7. Press firmly on the installed second left wheel stripe to adhere, then peel off the application film and guide.

8. Use steps 5 through 7 to install the third left wheel stripe in the same manner.
- When applying the third left wheel stripe, align the rear end of stripe with the guide of the first left wheel stripe. After application, peel off the guide of first left wheel stripe from the wheel.

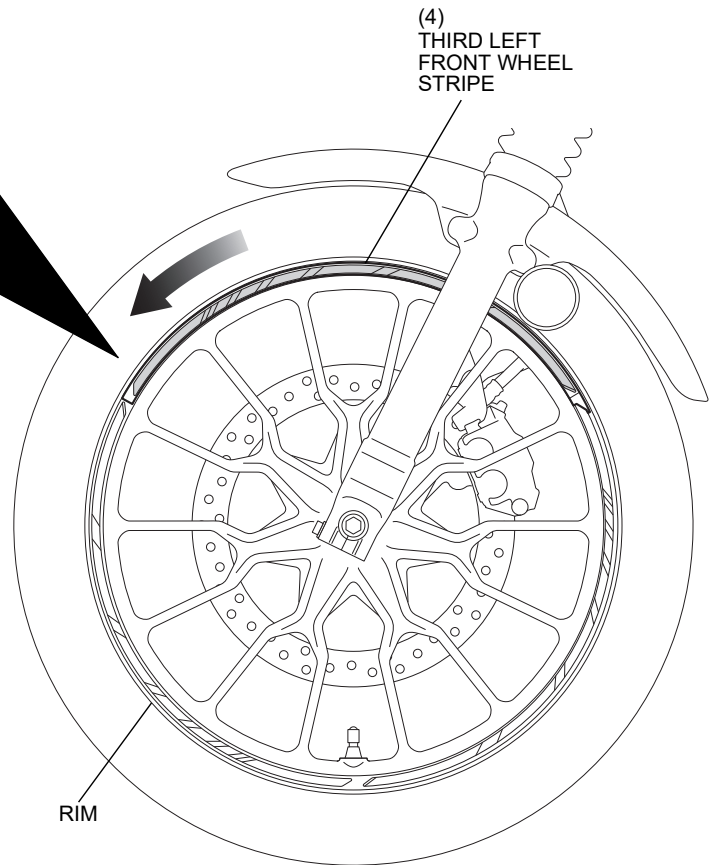
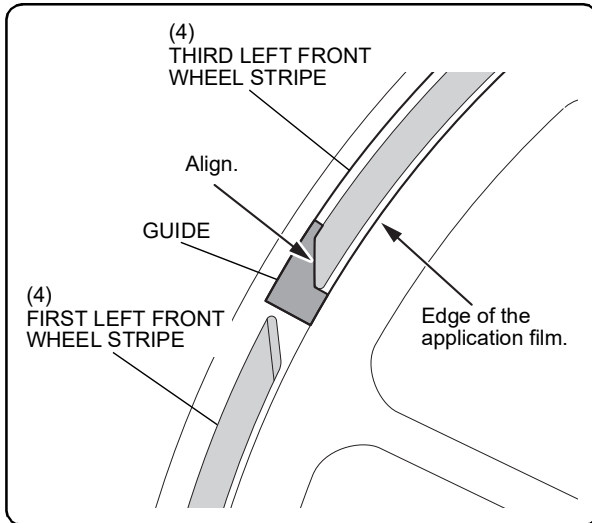

9. Install the right front wheel stripes in the same manner as the left side.
- Install the right front wheel stripes in the same position as the left side.

10. Install the rear side wheel stripes in the same manner as the front side.