

COMMON

- Added accessories can affect a motorcycle's stability, performance and safe riding speed.

ACCESSORY SOCKET

ACCESSORY SOCKET

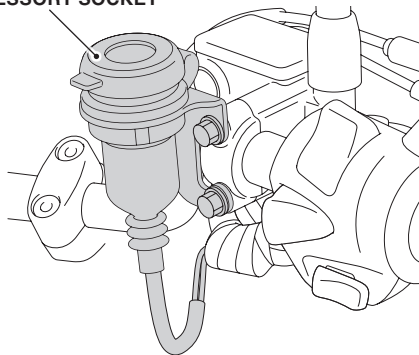

- The maximum power rating of connected accessories is 36W (12V, 3A).
- Use accessories with engine running to avoid discharging the battery.
- Do not use a cigarette lighter, as this can cause a malfunction.
- Cover the socket with the cap when the accessory socket is not used to prevent entry of foreign objects.
- Do not use the accessory socket when the motorcycle is being washed.
- Carefully secure any connected devices, as vibrations may cause them to shift unexpectedly.
- Make sure that the cable of device connected to the accessory socket does not disturb the steering operation or riding. Do not pinch the cable to prevent from being damaged.

FRONT FENDER

FRONT FENDER

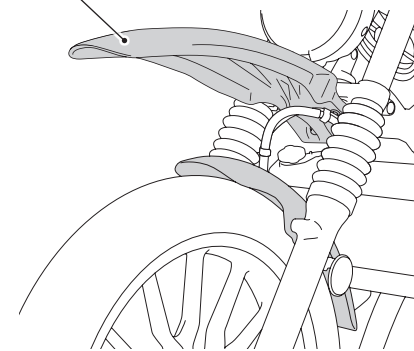

- When this accessory becomes dirty, rinse it thoroughly with cool water to remove loose dirt, then wipe with a clean cloth or sponge. Do not use a brush to clean this accessory as it may scratch the surface.
- Never use organic solvents such as gasoline, thinner and benzene to clean this accessory. Also do not use acid or alkaline cleaners to clean this accessory. Wipe up spilled brake or battery fluid at once as they may damage the surface.
- Handle this accessory with care. It can be damaged when it is bent excessively or is subject to strong shock or impact.

GRIP HEATER

HEATER SWITCH

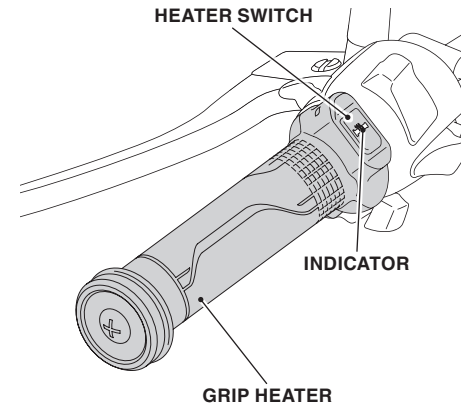

- Wear gloves to protect your hands from the grip heaters.
- Do not use the grip heater with the engine at idle for a long time. It may result in a low (or dead) battery.
- The grip heater warms up the right and left grips of the handlebar for comfortable riding on a cold day.
- Adjust the temperature by repeatedly pressing the switch. The temperature can be set five levels.
- The grip heater maintains the selected level when the ignition switch is turned off.
- The heater level is not changed if the ignition switch is turned to the OFF position within 5 seconds of changing the heater level.
- Do not leave the grip heater in the high position for a long time on a warm day.

INDICATOR

- Displayed when the grip heater is on.
- The selected heater level is indicated by the number of times the indicator blinks when the heater is turned on and the heater level is changed. For example, If you select heater level 5, the indicator blinks 5 times and repeats it 7 times.

HEADLIGHT VISOR / HEADLIGHT VISOR STRIPE

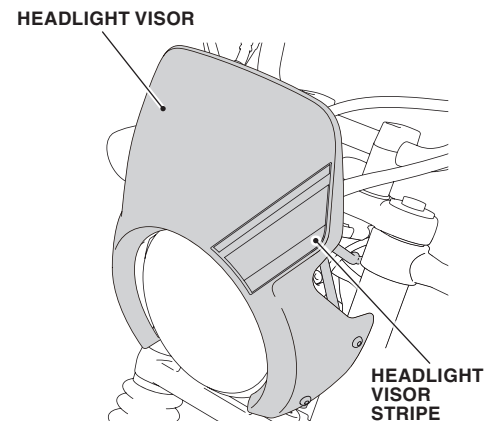

- When this accessory becomes dirty, rinse it thoroughly with cool water to remove loose dirt, then wipe with a clean cloth or sponge. Do not use a brush to clean this accessory as it may scratch the surface.
- Never use organic solvents such as gasoline, thinner and benzene to clean this accessory. Also do not use acid or alkaline cleaners to clean this accessory. Wipe up spilled brake or battery fluid at once as they may damage the surface.
- If the motorcycle is left covered for an extended period of time, park in the shade. Parking a covered motorcycle in direct sunlight can cause the headlight visor to deform due to heat buildup under the cover.
- Handle this accessory with care. It can be damaged when it is bent excessively or is subject to strong shock or impact.
- Select a firm, level surface when you park the motorcycle. Also bear in mind that strong wind can cause the motorcycle to topple to the ground.
- Do not wash the motorcycle with a high-pressure washer, as this may peel off the headlight visor stripe.

HOW TO USE THE GRIP HEATER

1. Start the engine.
2. Press the heater switch. The grip heater is on.
3. Select the heater level by pressing the heater switch.
4. To turn off the heater, select the OFF by pressing the heater switch.

- Also to turn off, press and hold the heater switch.

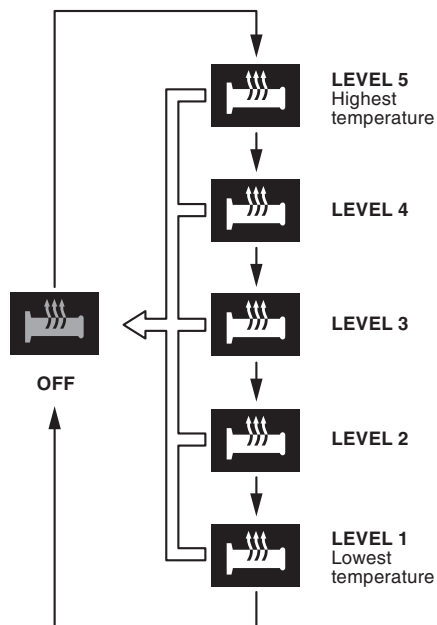

← Press the heater switch.

← Press and hold the heater switch.

HIGH SEAT

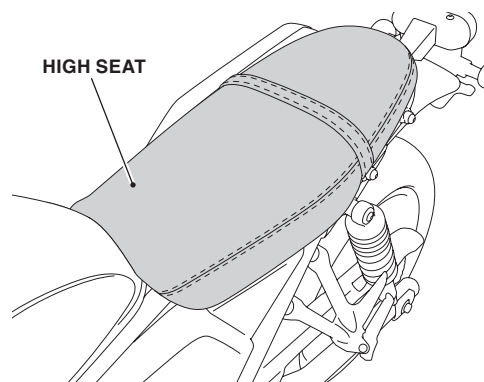

- When this accessory becomes dirty, rinse it thoroughly with cool water to remove loose dirt, then wipe with a clean cloth or sponge. Do not use a brush to clean this accessory as it may scratch the surface.
- Never use organic solvents such as gasoline, thinner and benzene to clean this accessory. Also do not use acid or alkaline cleaners to clean this accessory. Wipe up spilled brake or battery fluid at once as they may damage the surface.

KNUCKLE GUARD

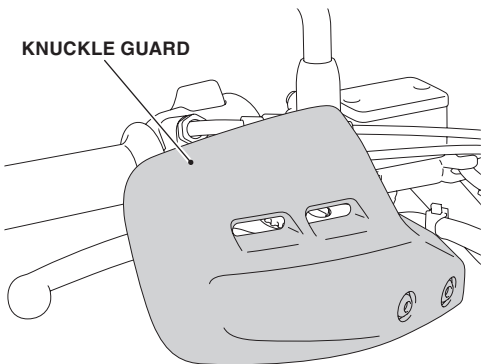

- When this accessory becomes dirty, rinse it thoroughly with cool water to remove loose dirt, then wipe with a clean cloth or sponge. Do not use a brush to clean this accessory as it may scratch the surface.
- Never use organic solvents such as gasoline, thinner and benzine to clean this accessory. Also do not use acid or alkaline cleaners to clean this accessory.
Wipe up spilled brake or battery fluid at once as they may damage the surface.
- Handle this accessory with care. It can be damaged when it is bent excessively or is subject to strong shock or impact.

RALLY STEP

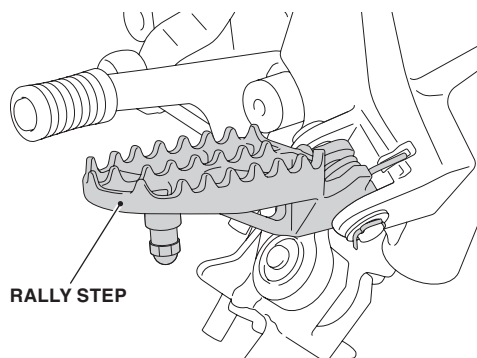

- When this accessory becomes dirty, rinse it thoroughly with cool water to remove loose dirt, then wipe with a clean cloth or sponge. Do not use a brush to clean this accessory as it may scratch the surface.
- Never use organic solvents such as gasoline, thinner and benzine to clean this accessory. Also do not use acid or alkaline cleaners to clean this accessory.
Wipe up spilled brake or battery fluid at once as they may damage the surface.

REAR CARRIER

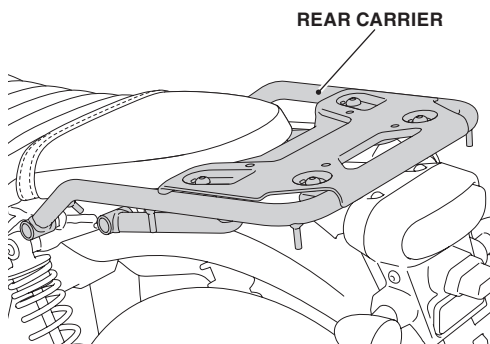

- The weight of the cargo must not exceed the following maximum load capacity:
5.0 kg (11.0 lb)
- When this accessory becomes dirty, rinse it thoroughly with cool water to remove loose dirt, then wipe with a clean cloth or sponge. Do not use a brush to clean this accessory as it may scratch the surface.
- Never use organic solvents such as gasoline, thinner and benzine to clean this accessory. Also do not use acid or alkaline cleaners to clean this accessory.
Wipe up spilled brake or battery fluid at once as they may damage the surface.

REAR CUSHION COVER

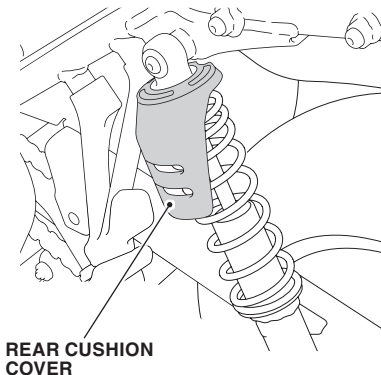

- When this accessory becomes dirty, rinse it thoroughly with cool water to remove loose dirt, then wipe with a clean cloth or sponge. Do not use a brush to clean this accessory as it may scratch the surface.
- Never use organic solvents such as gasoline, thinner and benzine to clean this accessory. Also do not use acid or alkaline cleaners to clean this accessory.
Wipe up spilled brake or battery fluid at once as they may damage the surface.

REAR SIDE COVER / REAR SIDE COVER STRIPE

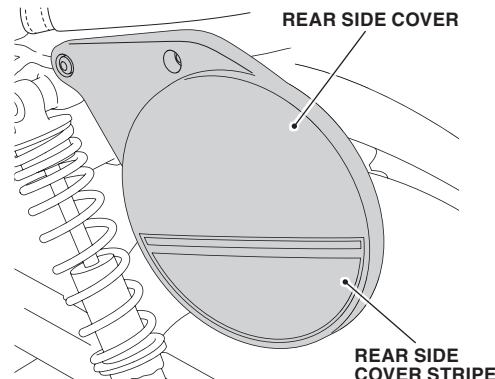

- When this accessory becomes dirty, rinse it thoroughly with cool water to remove loose dirt, then wipe with a clean cloth or sponge. Do not use a brush to clean this accessory as it may scratch the surface.
- Never use organic solvents such as gasoline, thinner and benzine to clean this accessory. Wipe up spilled brake or battery fluid at once as they may damage the surface.
- Handle this accessory with care. It can be damaged when it is bent excessively or is subject to strong shock or impact.
- Do not wash the motorcycle with a high-pressure washer, as this may peel off the rear side cover stripe.

RIGHT HANDLE LEVER

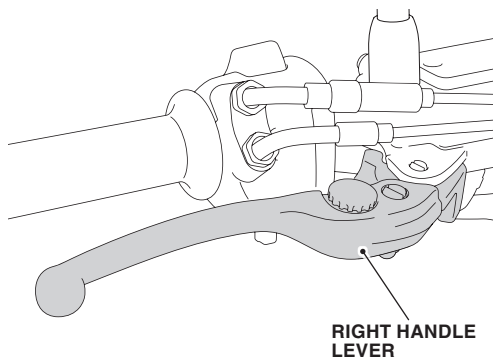

- When this accessory becomes dirty, rinse it thoroughly with cool water to remove loose dirt, then wipe with a clean cloth or sponge. Do not use a brush to clean this accessory as it may scratch the surface.
 - Never use organic solvents such as gasoline, thinner and benzine to clean this accessory. Also do not use acid or alkaline cleaners to clean this accessory.
- Wipe up spilled brake or battery fluid at once as they may damage the surface.

SADDLEBAG

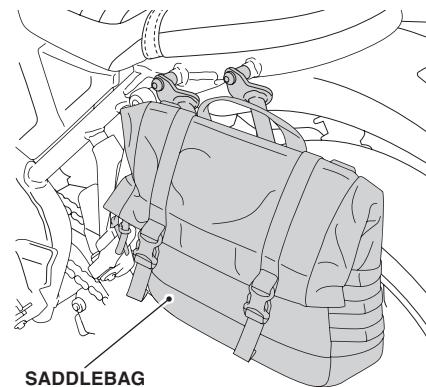

- The weight of the cargo must not exceed the following maximum weight capacity:
3.0 kg (6.6 lb)
 - Do not store valuables or fragile articles in the saddlebag.
 - Be sure that the saddlebag are installed securely before riding.
 - Before riding, confirm that fastener is closed and the strap is tightened.
 - To prevent burns, allow the engine, exhaust system, radiator, etc., to cool before installing and removing the accessory.
 - The saddlebag is hot while the engine is running and after it has been stopped (after riding etc.). Do not touch saddlebag for some time.
 - The saddlebag are not perfectly watertight, and water may enter when washing the motorcycle, when it rains, etc.
 - Never use organic solvents such as gasoline, thinner and benzine to clean this accessory. Also do not use acid or alkaline cleaners to clean this accessory.
- Wipe up spilled brake or battery fluid at once as they may damage the surface.
- If this accessory becomes completely wet (water has soaked through the material), remove this accessory and allow it to air dried at room temperature. Never dry this accessory in a dryer, in front of a heater, or near a fireplace.
 - Check that saddlebag and straps do not interfere with the motorcycle body. Pay special attention to hot parts and rotating parts.
 - The inner bag is made of a material that is resistant to water from the outside, but is not completely waterproof due to its structure. There is a possibility of internal condensation or inundation due to the influence of heat while riding, running in the rain for a long time, or motorcycle washing.
 - Due to the nature of the inner bag, do not store dangerous items, sharp objects, protrusions, or valuables.

ADJUSTING METHOD

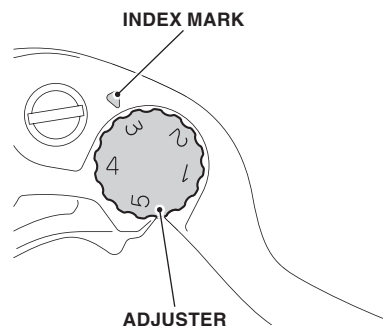

1. Turn the adjuster until the numbers align with the index mark while pushing the lever forward in the desired position.
 - **After adjustment, check that the lever operates correctly before riding.**

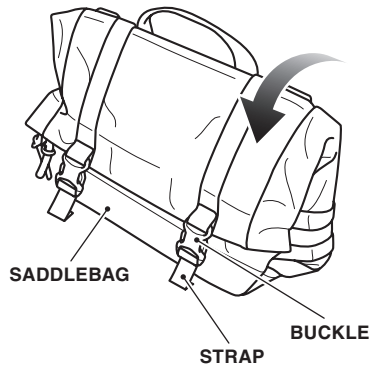

HOW TO INSTALL THE SADDLEBAG

1. Zip up the saddlebag.
2. Fold the bag as shown. Secure the buckles and tighten the strap.

<BACKSIDE OF THE SADDLEBAG>

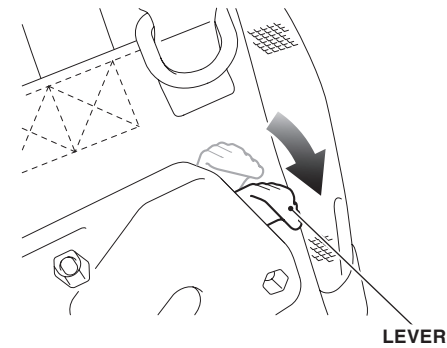

HOW TO REMOVE THE SADDLEBAG

1. Push down the lever as shown and remove the saddlebag.

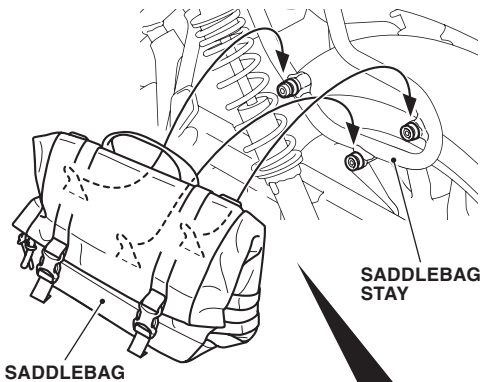

3. Install the saddlebag as shown.
4. Check that the saddlebag is installed securely.
 - The saddlebag can come off during riding unless it is mounted securely.

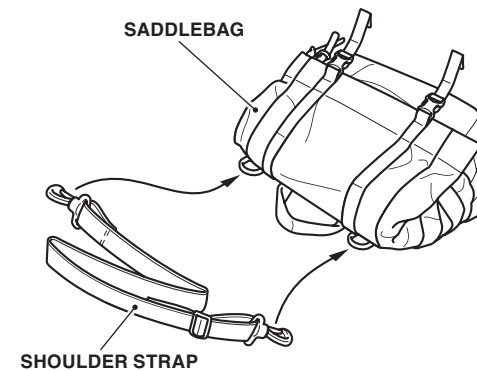

HOW TO USE THE SHOULDER STRAP

1. Hook the shoulder strap as shown.
 - Always store the shoulder strap when not in use.
 - Use the shoulder strap when carrying the saddlebag.

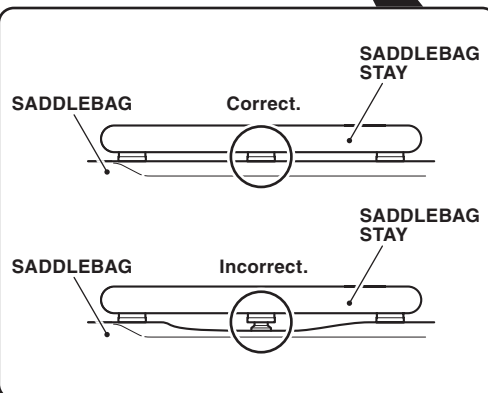

HOW TO STORE THE INNER BAG

1. Store the inner bag in the saddlebag.

TANK PAD CENTER

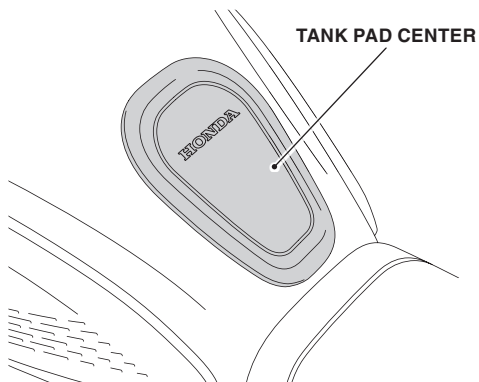

- When this accessory becomes dirty, rinse it thoroughly with cool water to remove loose dirt, then wipe with a clean cloth or sponge. Do not use a brush to clean this accessory as it may scratch the surface.
 - Never use organic solvents such as gasoline, thinner and benzine to clean this accessory. Also do not use acid or alkaline cleaners to clean this accessory.
- Wipe up spilled brake or battery fluid at once as they may damage the surface.

TOP BOX / BACKREST

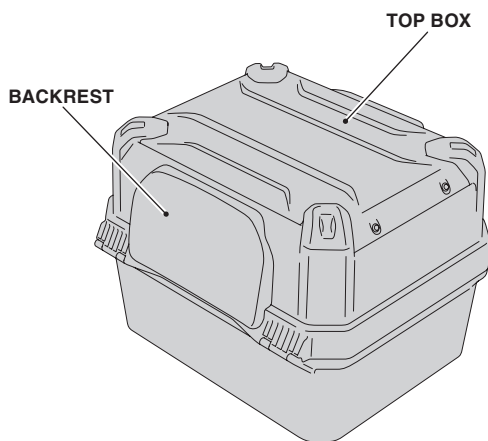

- The weight of the cargo must not exceed the following maximum weight capacity:
3.0 kg (6.6 lb)
 - Be sure that the top box is installed securely before riding.
 - Before riding, confirm that lid is closed and remove the key.
 - The top box is not perfectly watertight, and water may enter when washing the motorcycle, when it rains, etc.
 - To prevent burns, allow the engine, exhaust system, radiator, etc., to cool before installing and removing the accessory.
 - Do not store valuables or fragile articles in the top box.
 - Don't place a heavy object on the opened lid or apply an excessive force from the top of opened lid.
 - Open and close the lid gently.
 - If the top box gets dirty, slightly push and clean it with a sponge or a shop towel moistened with a neutral detergent, remove the detergent with clean water, and then wipe them dry with a clean sponge or shop towel.
 - Never use organic solvents such as gasoline, thinner and benzine to clean this accessory. Also do not use acid or alkaline cleaners to clean this accessory.
- Wipe up spilled brake or battery fluid at once as they may damage the surface.
- When the surface of backrest turns white, wipe away with a shop towel or like with water.

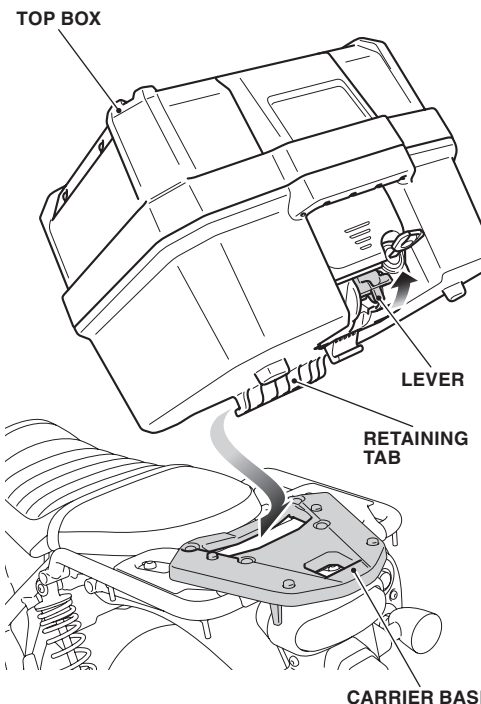

HOW TO INSTALL THE TOP BOX

1. Insert the key and release the lock by turning the key clockwise.

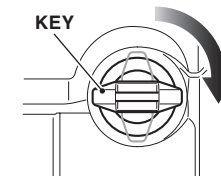

2. Lift the lever as shown, and insert the retaining tab of the top box into the hole of the carrier base.

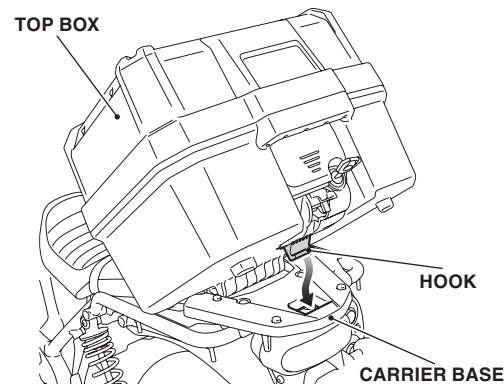

3. Position the hook of the top box on the carrier base as shown.

<HOOK POSITION>

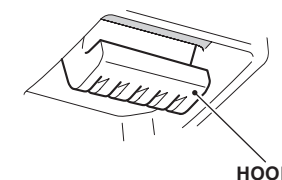

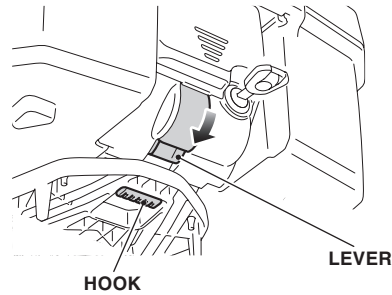

4. Secure the hook by pressing the lever down as shown.

<HOOK POSITION>

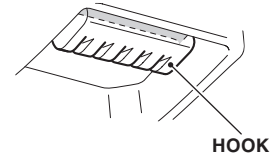

HOW TO REMOVE THE TOP BOX

1. Remove the top box in the reverse order of installation.

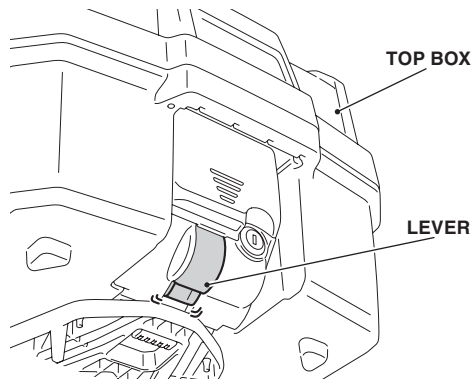

5. Lock the top box by turning the key counter-clockwise.

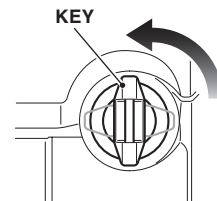

6. Remove the key. Be sure that lever cannot be released.

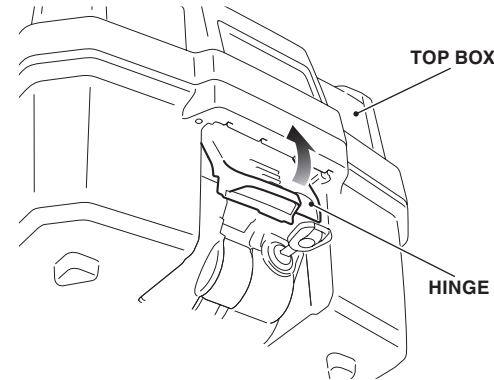

HOW TO OPEN THE TOP BOX

1. Insert the key and release the lock by turning the key clockwise.

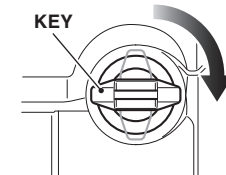

2. Pull the hinge up as shown.

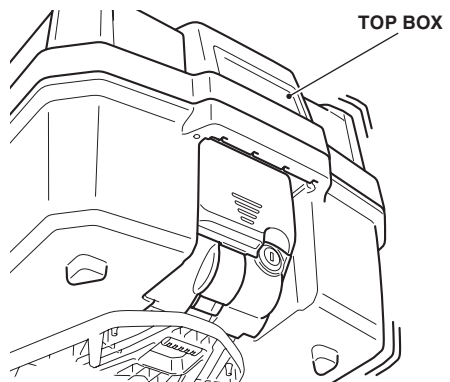

7. Check that the top box is installed securely by swinging the top box taking care not to fall the motorcycle down.

- The top box can come off during riding unless it is mounted securely.

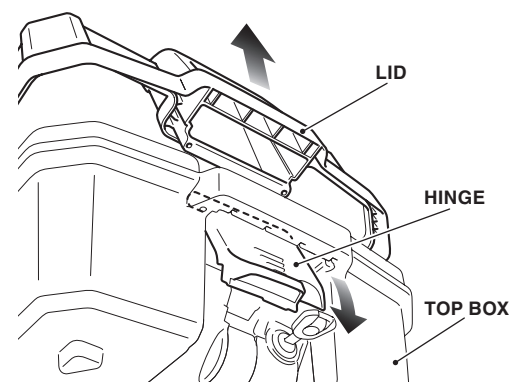

3. Raising the upper part of hinge, move the hinge down as shown and open the lid.

HOW TO CLOSE THE TOP BOX

1. Confirm that the key position is as shown.

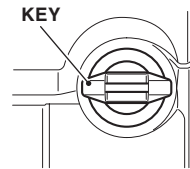

2. Close the lid.

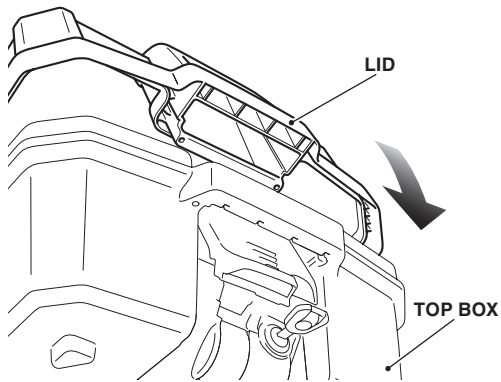

3. Holding the upper part of the hinge, push the hinge down.
 - Be careful not to have the stored item pinched when the top box is closed.

4. Lock the top box by turning the key counter-clockwise.

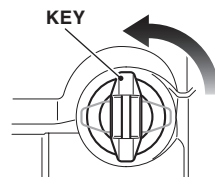

5. Remove the key.
 - Make sure the lid and hinge are locked down securely.

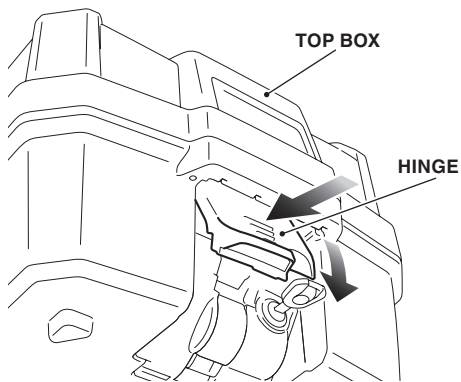

WHEEL STRIPE

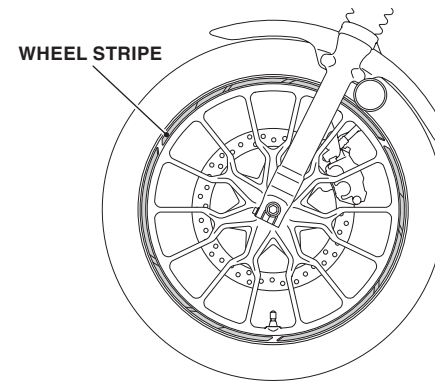

HOW TO STORE THE TOP BOX INNER BAG

1. Open the top box and store the top box inner bag.
2. Close the top box.
 - Be careful not to have the stored item pinched when the top box is closed.

- When this accessory becomes dirty, rinse it thoroughly with cool water to remove loose dirt, then wipe with a clean cloth or sponge. Do not use a brush to clean this accessory as it may scratch the surface.
- Never use organic solvents such as gasoline, thinner and benzene to clean this accessory. Also do not use acid or alkaline cleaners to clean this accessory. Wipe up spilled brake or battery fluid at once as they may damage the surface.
- Do not wash the motorcycle with a high-pressure washer, as this may peel off the wheel stripes.

SAFETY INFORMATION

The following sentences show the label meaning.
Some labels warn you of potential hazards that could cause serious injury.
Others provide important safety information.
Read this information carefully and don't remove the label.

If a label comes off or becomes hard to read, contact your Honda dealer for a replacement.

There is a specific symbol on each label. The meanings of each symbol and label are as follows.



Read the use and care information in installation instructions or genuine accessory user's guide carefully.
Read the **LOAD LIMITS AND GUIDELINES**, and **TYRES** sections in owner's manual.



DANGER (with RED background)

You **WILL** be **KILLED** or **SERIOUSLY HURT** if you don't follow instructions.

WARNING (with ORANGE background)

You **CAN** be **KILLED** or **SERIOUSLY HURT** if you don't follow instructions.

CAUTION (with YELLOW background)

You **CAN** be **HURT** if you don't follow instructions.

Refer to this information for the meanings of the symbols shown on the accessory.

CARRIER WARNING LABEL



Regarding the maximum loading capacity.
Read the use and care information carefully in each of the accessory installation instructions or genuine accessory user's guide.